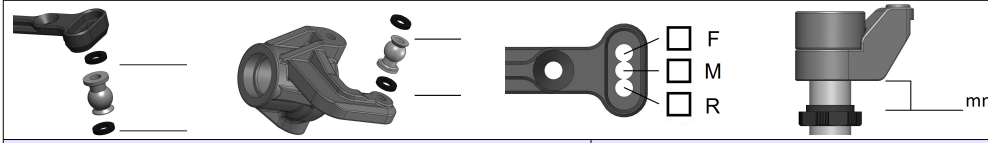

SETUP SHEET

Name:	Date:	Event:
Track Conditions:	Outdoor Open Loose/Loamy Dusty High Bite	Low Bite Rough
Indoor Tight Smooth Hard Packed Wet Dry Med Bite		Blue Groove

BUMPSTEER/ACKERMANN/SERVO SAVER SHOCKS

 <div style="display: flex; justify-content: space-around; margin-top: 10px;"> <div style="text-align: center;"> <input type="checkbox"/> F <input type="checkbox"/> M <input type="checkbox"/> R </div> <div style="text-align: center;"> <input type="checkbox"/> mm </div> </div>	<table border="1" style="width: 100%; border-collapse: collapse;"> <tr> <td></td> <td style="text-align: center;">Front</td> <td style="text-align: center;">Rear</td> </tr> <tr> <td>Piston</td> <td></td> <td></td> </tr> <tr> <td>Oil</td> <td></td> <td></td> </tr> <tr> <td>Bladder</td> <td></td> <td></td> </tr> <tr> <td>Spring</td> <td></td> <td></td> </tr> <tr> <td>Length/ Droop</td> <td></td> <td></td> </tr> </table>		Front	Rear	Piston			Oil			Bladder			Spring			Length/ Droop		
	Front	Rear																	
Piston																			
Oil																			
Bladder																			
Spring																			
Length/ Droop																			

FRONT SUSPENSION

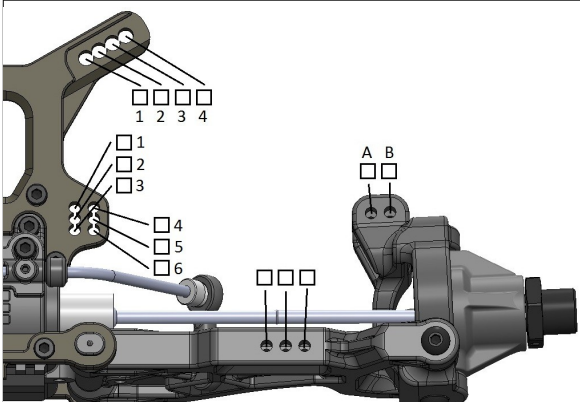
 <div style="display: flex; justify-content: space-around; margin-top: 10px;"> <div style="text-align: center;"> <input type="checkbox"/> 1 <input type="checkbox"/> 2 <input type="checkbox"/> 3 <input type="checkbox"/> 4 <input type="checkbox"/> 5 <input type="checkbox"/> 6 </div> <div style="text-align: center;"> <input type="checkbox"/> A <input type="checkbox"/> B </div> </div> <div style="display: flex; justify-content: space-around; margin-top: 10px;"> <div style="text-align: center;"> <input type="checkbox"/> 12 <input type="checkbox"/> 11 <input type="checkbox"/> 10 </div> <div style="text-align: center;"> <input type="checkbox"/> 1FRWD <input type="checkbox"/> 0 <input type="checkbox"/> 1BACK </div> </div>	<table border="1" style="width: 100%; border-collapse: collapse;"> <tr> <td></td> <td style="text-align: center;">Front</td> <td style="text-align: center;">Rear</td> </tr> <tr> <td>Ride Height</td> <td></td> <td></td> </tr> <tr> <td>Camber</td> <td></td> <td></td> </tr> <tr> <td>Toe</td> <td></td> <td></td> </tr> <tr> <td>Sway Bar</td> <td></td> <td></td> </tr> </table>		Front	Rear	Ride Height			Camber			Toe			Sway Bar			<table border="1" style="width: 100%; border-collapse: collapse;"> <tr> <td></td> <td style="text-align: center;">Front</td> <td style="text-align: center;">Rear</td> </tr> <tr> <td>Brand</td> <td></td> <td></td> </tr> <tr> <td>Compound</td> <td></td> <td></td> </tr> <tr> <td>Insert</td> <td></td> <td></td> </tr> <tr> <td>Wheel</td> <td></td> <td></td> </tr> </table>		Front	Rear	Brand			Compound			Insert			Wheel		
	Front	Rear																														
Ride Height																																
Camber																																
Toe																																
Sway Bar																																
	Front	Rear																														
Brand																																
Compound																																
Insert																																
Wheel																																

REAR BRACES

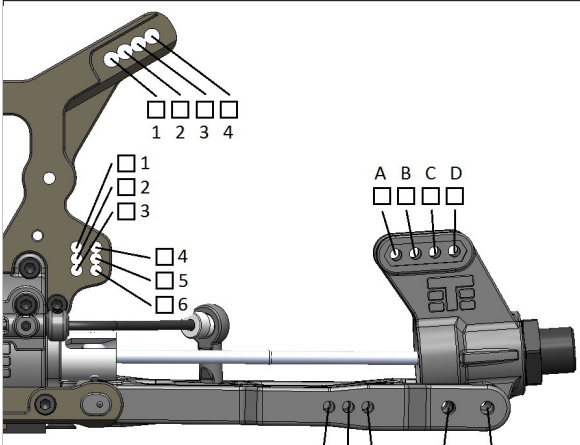
 <div style="display: flex; justify-content: space-around; margin-top: 10px;"> <div style="text-align: center;"> <input type="checkbox"/> 1 <input type="checkbox"/> 2 <input type="checkbox"/> 3 <input type="checkbox"/> 4 <input type="checkbox"/> 5 <input type="checkbox"/> 6 </div> <div style="text-align: center;"> <input type="checkbox"/> A <input type="checkbox"/> B <input type="checkbox"/> C <input type="checkbox"/> D </div> </div> <div style="display: flex; justify-content: space-around; margin-top: 10px;"> <div style="text-align: center;"> <input type="checkbox"/> 1 <input type="checkbox"/> 2 <input type="checkbox"/> 3 </div> <div style="text-align: center;"> <input type="checkbox"/> 1.5 <input type="checkbox"/> 2.5 <input type="checkbox"/> 3.5 </div> </div>	<table border="1" style="width: 100%; border-collapse: collapse;"> <tr> <td colspan="3">Notes:</td> </tr> <tr> <td style="text-align: center;"><input type="checkbox"/> Front</td> <td style="text-align: center;"><input type="checkbox"/> Middle</td> <td style="text-align: center;"><input type="checkbox"/> Rear</td> </tr> <tr> <td colspan="3">(Front is always recommended)</td> </tr> </table>	Notes:			<input type="checkbox"/> Front	<input type="checkbox"/> Middle	<input type="checkbox"/> Rear	(Front is always recommended)		
Notes:										
<input type="checkbox"/> Front	<input type="checkbox"/> Middle	<input type="checkbox"/> Rear								
(Front is always recommended)										

WHEELBASE DIFFS

	<table border="1" style="width: 100%; border-collapse: collapse;"> <tr> <td></td> <td style="text-align: center;">Front</td> <td style="text-align: center;">Center</td> <td style="text-align: center;">Rear</td> </tr> <tr> <td></td> <td></td> <td></td> <td></td> </tr> </table>		Front	Center	Rear				
	Front	Center	Rear						

DRIVETRAIN

Gear Ratio: _____ / _____	Spur: <input type="checkbox"/> Metal <input type="checkbox"/> Plastic
<input type="checkbox"/> Pinion <input type="checkbox"/> Long Shank <input type="checkbox"/> Traktion <input type="checkbox"/> Clutch	Shoes: Springs:
<input type="checkbox"/> Mech. Brake <input type="checkbox"/> Motor Brake	Radio Notes:

NOTES: