

Name: \_\_\_\_\_ Date: \_\_\_\_\_ Event/Track: \_\_\_\_\_

Track Conditions: Outdoor  Indoor  Wet  Dry  High Bite  Low Bite  Rough   
 Smooth  Hard Packed  Loose/Loamy  Blue Groove

### Bumpsteer/Ackerman/Servo Saver/Steering Stop:

# washers  
 over  
 under  
 ballstud

# washers  
 over  
 under  
 ballstud

front  
 middle  
 rear

### Front End:

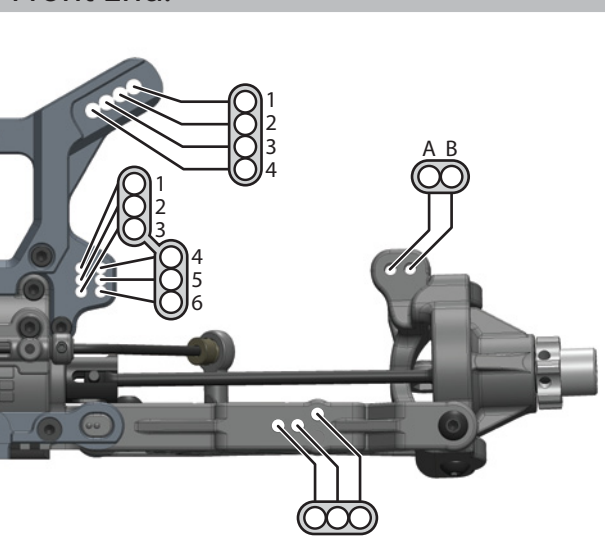

#### Front Outer (Sweep)

1.0F  0.5F  0.0  0.5R  1.0R

#### Front Inner (Kick Up)

10.0°  10.5°  11.0°  11.5°  12.0°

# of turns from fully tightened

# washers

### Suspension:

	FRONT	REAR
RIDE HEIGHT:		
TOE (in/out):		
CAMBER:		
CASTER:		Deg°
SHOCK LENGTH (DROOP):		
SWAY BAR:		

NOTES:

### Body/Wing:

BODY:	
WING:	

### Rear End:

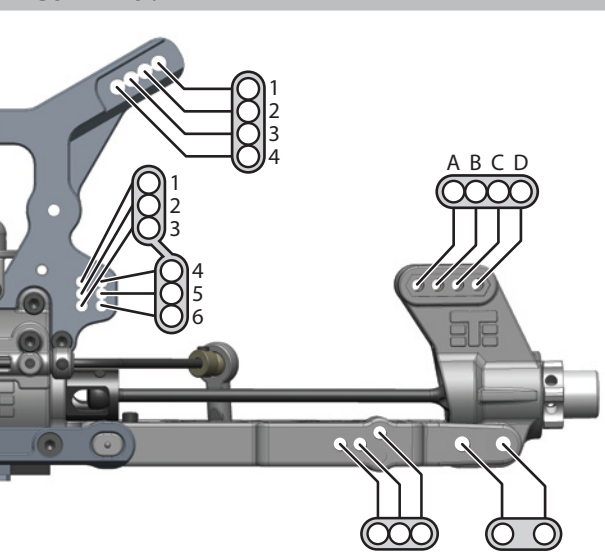

#### Rear Outer (Toe In)

2.5°  3.0°  3.5°  4.0°  4.5°

#### Rear Inner (Anti-Squat)

3.0°  2.5°  2.0°  1.5°  1.0°

(DOWNFORCE POSITION)

### Wheelbase:

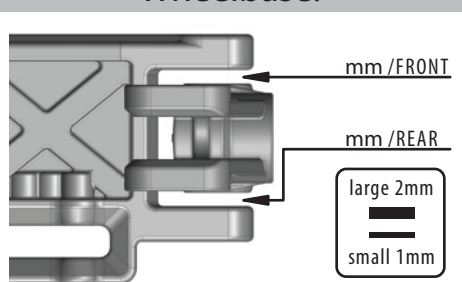

Notes:

### Shocks:

	FRONT	REAR
STD/EMUL/VENT:		
PISTON:		
OIL:		
BLADDER:		
REBOUND:	%	%
SPRING:		

NOTES:

### Tires / Wheels:

	FRONT	REAR
BRAND:		
TREAD:		
COMPOUND:		
INSERT:		
WHEEL:		

NOTES:

### Differential Oil:

	FRONT	CENTER	REAR

NOTES:

### Equipment:

BATTERY:	
ESC:	
MOTOR:	
RADIO:	
SERVO(s):	

NOTES:

### Drivetrain:

PINION/BELL:	(teeth)	
SPUR GEAR:	Metal <input type="checkbox"/>	Plastic <input type="checkbox"/>
BRAKES:	Mech <input type="checkbox"/>	Motor <input type="checkbox"/>
TRAKTION DRIVE:	Y/N	/ Springs

NOTES: